



Via Mario Villa, 210
20099 Sesto San Giovanni (MI), Italy
Tel. +39 02 24 10 50 01
www.ge.com

IS 2608 GB
Page 1 of 18

OIL TO AIR BUSHINGS SERIES PNO

VOLTAGE FROM 52 kV TO 170 kV



PORCELAIN TYPE

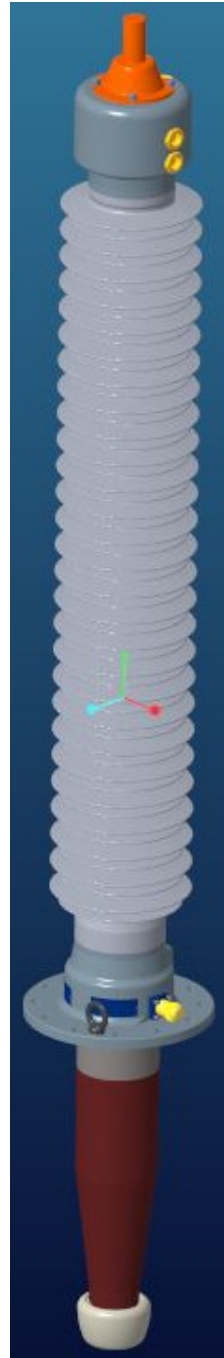

COMPOSITE TYPE

**INSTRUCTION FOR STORAGE, TRANSPORTATION,
INSTALLATION AND MAINTENANCE**



**OIL-TO-AIR BUSHINGS SERIES PNO
VOLTAGE FROM 52 TO 170 kV**

IS 2608 GB

Page 2 of 18

Instruction Manual

Rev. D – Aug. 2019

INDEX

1	DESCRIPTION	3
1.1	GENERAL	3
1.2	SAFETY	3
1.3	TECHNICAL CHARACTERISTICS	3
2	PACKING AND STORAGE	5
2.1	PACKING	5
2.2	ACCEPTANCE	6
2.3	STORAGE.....	6
3	LIFTING AND TRANSPORTATION	7
3.1.	PACKED BUSHING	7
3.2.	UNPACKED BUSHING	7
3.3.	SHIPMENT TO THE END USER.....	8
4	INSTALLATION ON THE TRANSFORMER	8
4.1.	DRAW LEAD CONNECTION.....	8
4.2.	DRAW ROD CONNECTION	9
4.3.	BOTTOM CONNECTION.....	9
4.4.	OIL SIDE SHIELD.....	10
4.5.	ARCING HORNS.....	10
4.6.	OIL FILLING OF THE TUBE OF THE BUSHING.....	11
4.7.	CONNECTION TO BUCHHOLZ RELAY	11
5	TEMPERATURE LIMITS	11
6.	SERVICE AND MAINTENANCE	11
6.1.	METAL PARTS.....	11
6.2.	CHECKS AFTER INSTALLATION	11
6.3.	DISASSEMBLY OF THE BUSHING	13
6.4.	MAINTENANCE	13
6.5.	MEASUREMENT OF DIELECTRIC LOSSES	13
6.6.	CHECKS ON OLD BUSHINGS	14
6.7.	EXTRAORDINARY CHECKS.....	14
6.8.	OIL SAMPLING	14
7.	DISPOSAL AT THE END OF LIFETIME	18

Rev. D	August 2019
Rev. C	November 2017
Rev. B	March 2015
Rev. A	July 2006
First edition	June 1999



OIL-TO-AIR BUSHINGS SERIES PNO VOLTAGE FROM 52 TO 170 kV

IS 2608 GB

Page 3 of 18

Instruction Manual

Rev. D – Aug. 2019

1 DESCRIPTION

1.1 GENERAL

These instructions are applicable to the oil paper condenser type bushings of the series:

“PNO” for rated voltage 52 to 170 kV

according to IEC 60137 Standard “Insulated bushings for alternating voltages above 1000 V”, and give all general information to be followed from the receipt of bushings until their installation on the transformer. Other information is given regarding their service and maintenance.

Design, components and manufacturing technology guarantee an average lifetime longer than 30 years, in normal operation conditions.

The designation of the bushing is the following:

PNO 145. 650. 1250

P	Condenser bushings (“P” from Italian word “Passante”)
N	Normal tail type, oil to air
O	Oil paper insulation (OIP)
145	Rated voltage (in kV)
650	BIL class -Basic Insulation Level (in kV).
1250	Rated current (in A)

1.2 SAFETY

This manual must be available to the personnel responsible of the installation, operation and maintenance of the bushings.

The installation, operation and maintenance of the bushings, present conditions of no safety and it is necessary to follow carefully specific procedures and instructions. No compliance with these procedures and instructions can involve very severe and dangerous conditions for the personnel and the property.

Please follow carefully all the instructions of the manual and pay attention to the WARNING (severe hazard), and CAUTION (minor hazard) signs.

1.3 TECHNICAL CHARACTERISTICS

These bushings are capacitance graded type with oil impregnated paper insulation, designed for use on power transformers, for installation with inclination up to 45° from the vertical.

They are provided for operation with the upper part in the open air (normally or highly polluted atmosphere) and with the lower part immersed in the transformer oil. The schematic design is showed in fig. 1.

1.3.1 INSULATION

The main electrical insulation is given by a condenser body, made of a continuous sheet of pure Kraft paper, wound around a tube.

Heated cylinders and infrared rays dry the paper during winding, to reduce the water content in the paper to 1% maximum.

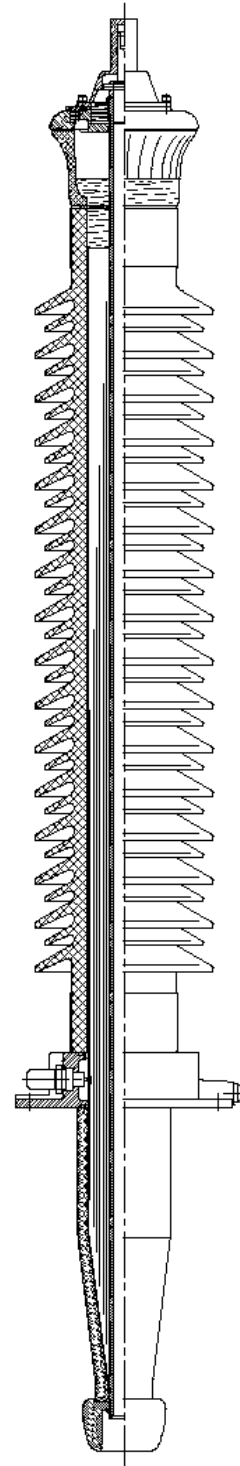

Fig. 1



OIL-TO-AIR BUSHINGS SERIES PNO VOLTAGE FROM 52 TO 170 kV

IS 2608 GB

Page 4 of 18

Instruction Manual

Rev. D – Aug. 2019

During the winding a sequence of aluminium foils, cylindrical shape and coaxial disposition, is inserted between the layers of paper. These foils grade the best possible distribution of the radial and longitudinal electrical gradient between the conductor and the fixing flange, which is grounded.

The winding is made by computer-controlled machines, with simultaneous machining to the final shape. After winding the bushing is assembled and placed into an oven at 105 °C, treated under vacuum (each bushing individually), kept at $4 \cdot 10^{-2}$ mm Hg for some days and impregnated with oil (having max. humidity content of 3 ppm and suitably degassed). The impregnation is made under pressure in order to obtain the best impregnation and to test the perfect tightness.

After the impregnation process the head of bushing is filled with a nitrogen cushion. All this process is automatic, and computer controlled.

1.3.2 AIR SIDE

The air side envelope is made of porcelain, brown colour (upon request resin fibre-glass envelope covered with silicone sheds), creepage distance for very high-polluted atmosphere (VHP): 31 mm/kV.

The shed configuration is alternated type (small-large sheds). This is the most effective solution as proved by salt tests and the profile of sheds complies with the recommendations of Standards.

One-piece porcelain is used for bushings up to 170 kV.

In case of special longer creepage distance or in case of service at altitude higher than 1000 m more pieces can be glued together in order to comply with the requirement.

1.3.3 OIL SIDE

The oil side envelope is made of moulded epoxy resin. This type of housing has been employed by PASSONI & VILLA for the first time in 1963, for the manufacturing of the transformer side envelope in the re-entrant type bushing. The epoxy resins are bi-components type, i.e. consist of a resin base and a hardener, the charge material is quartz sand. The epoxy resin envelopes have shapes, thickness and dimension tolerances not possible to be achieved by porcelains.

Versions with under flange sleeve in oil side for CT accommodation are available upon request. In this case the grounded part can be obtained or with a metallic tube or directly by the last metallic layer inside the condenser body.

1.3.4 HV TERMINAL

Bushings draw lead or draw rod type have a removable HV terminal. This terminal is coupled to the copper lug or the draw rod by means of multi-blades contact and it is fixed on the head by means of four screws.

In the bottom connection bushing (1600 A), the inner non-removable rod makes also the function of HV terminal. Normally HV terminal is made of aluminium

without any surface treatment. It can be supplied in copper, tinned or silvered upon request.

1.3.5 HEAD AND OIL LEVEL INDICATION

The metal components of the head are made of aluminium alloy casting. Bushings with porcelain insulators have an oil head reservoir, cylindrical prismatic shape, made of borosilicate glass, UV filter, which allows an easy check of the level also at distance, from any sight angle and in all the range of operating temperatures.

1.3.6 OIL SIDE SHIELD

The bottom end of the bushing is shielded by a suitable integrated shield, made of an aluminium alloy casting. It has the function of reducing the dielectric strength in oil and screening the connection between the lead coming from the transformer winding and the bushing itself. The shield of bushing with bottom connection execution can be removable upwards as option and is made in aluminium sheet.

The condition of the transformer oil must be with less than 15 ppm water content for voltages up to 170 kV, less than 10 ppm for voltages over 170 kV, and dielectric strength higher than 60 kV, according to IEC 60156.

1.3.7 FLANGE

The flange is made of aluminium casting, equipped with the following accessories:

- Lifting holes;
- Power factor tap (tested at 2 kV for 60 s), for the measurement of the dielectric characteristics;
- Buchholz relay connection ($\frac{1}{2}$ " GAS plug for air outlet from the transformer);
- Voltage tap upon request for 245 kV bushings (tested at 10 kV for 60 s);
- Oil sampling plug (for 145 and 170 kV bushings);

1.3.8 GASKETS

Made of fluorocarbon rubber elastomer, O-ring type. They are compatible with impregnating oil of bushing and hot mineral oil of the transformer.

Flat gaskets are fitted concentrically to o-rings, to prevent a direct contact from the metal parts and the porcelain envelope.

For special requirements regarding low ambient temperatures (up to -55°C) special o-rings are foreseen, made of Fluor-silicone mixtures.

1.3.9 ASSEMBLING

The mechanical coupling among all parts of the bushing is made by means of springs placed into the



OIL-TO-AIR BUSHINGS SERIES PNO VOLTAGE FROM 52 TO 170 kV

IS 2608 GB

Page 5 of 18

Instruction Manual

Rev. D – Aug. 2019

head of bushing (normal cantilever “N”). Bushings 245 kV employ cemented porcelain. For Heavy cantilever requirement (“H”), bushings up to 170 kV are also available with cemented porcelain. The cemented used is a monocalcic aluminized type, curing quick. All the cement surfaces in contact with the external ambient are protected by means of a silicone sealing.

1.3.10 TYPE OF DIELECTRIC

The impregnation is made with a top quality inhibited super grade mineral oil, fully complying to Standards IEC 60296 and ASTM D3487, with the following outstanding characteristics:

- High dielectric strength (>70 kV/2,5mm);
- Very good low temperature properties (pour point typically <-60 °C);
- Low viscosity even at the lowest temperatures;
- Very good oxidation stability;
- Extremely good heat transfer.

1.3.11 NAME PLATE

Each bushing is provided with a name plate, with serial number and all the electrical data, in accordance with the prescription of IEC Standards. The plate is made of aluminium and is fixed on the flange by nails. The plate (fig. 2) includes the following information:

Name plate detail

PASSONIVILLA	MILAN ITALY	SERIAL NR.	M/YEAR
PASSANTE-BUSHING-TRAVERSEE-DURCHFUEHRUNG			
TYPE			
STD REF.			50-60Hz
Um	kV	BIL/SIL/AC	kV Ir A
C1	pF	C2	pF P.F. % AT 10kV/20°C
	kg		

Fig. 2

- 1 – Serial number
- 2 – Month & year of production
- 3 – Type of bushing
- 4 – Standard reference
- 5 – Rated frequency
- 6 – Max. system voltage
- 7 – Insulating voltages
- 8 – Rated current
- 9 – Main Capacitance measured value (*)
- 10 – Tap capacitance measured value (*)
- 11 – Dissipation factor measured value (*)
- 12 – Max. mounting angle
- 13 – Weight

(*) For bushings having Um greater than 100 kV

The month is indicated by a code, as follows:

- | | | |
|--------------|------------|---------------|
| A = January | E = May | P = September |
| B = February | H = June | R = October |
| C = March | L = July | S = November |
| D = April | M = August | T = December |

2 PACKING AND STORAGE

2.1 PACKING

After the tests, before packing, the lower part of the bushing is cleaned from the oil and the porcelain or the composite insulator from the dust.

Bushings can be packed in horizontal position.

This grants that the dimensions of cases are smaller and the transportation less costly. Bushings up to 170 kV are normally shipped in cases of three pieces.

CAUTION

It is necessary that **the bushing equipped with porcelain insulator** is laid down with the PF tap placed downwards, as indicated in fig.3.

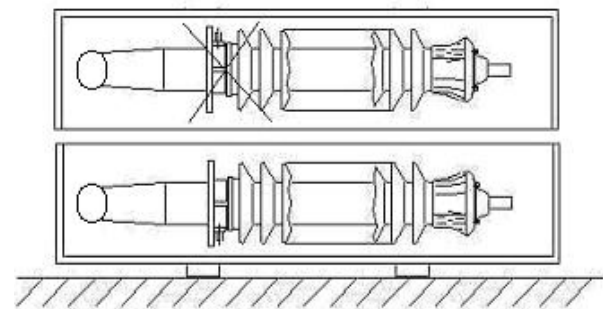

Fig. 3

To remind the operator on this precaution, the label of fig. 4 is stuck on the bushing head.

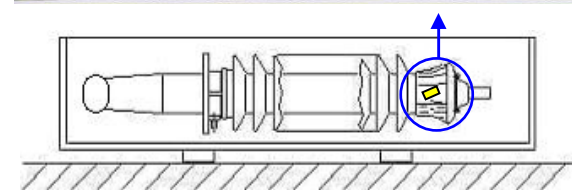



Fig. 4

	OIL-TO-AIR BUSHINGS SERIES PNO VOLTAGE FROM 52 TO 170 kV	IS 2608 GB
Page 6 of 18	Instruction Manual	Rev. D – Aug. 2019

2.2 ACCEPTANCE

Upon receipt of the goods the Customer should operate as follows:

- Check the external surfaces of the packing cases:
 - No sign of damage shall be found;
 - The shock and tilt indicators, placed in the external part of each packing case (fig. 5 and 5A), must be NOT ACTIVATED.



Fig. 5

If a shock or tilt indicator is red (ACTIVATED) don't refuse shipment, make a notation on delivery receipt and inspect for damage as follow:

- Open the packing case by removing its cover;
- Make sure that the anchoring elements are in order and securely fixed;
- Make sure that the oil level is correct;
- Make sure that there are no leaks from the bushings, especially in the joints between porcelain and metal parts and that there are no breaks or broken parts. Please consider that each bushing has been tested with the tail immersed in oil, therefore some oil traces can be found.

In case any damage is found, leave in original packaging and request an immediate inspection from carrier within 15 days of delivery. Moreover give the forwarding agent a written claim and notify our Company with the details of the packing list, including the number of the case and the serial number of the bushing.



Fig. 5A

2.3 STORAGE

Every bushing is protected with a polyethylene bag hermetically sealed and containing a silicagel bag; in such a way the bushing is protected in dry air against the humidity of the ambient.

Although there is no preclusions for the bushings remaining in the open air, it is better to store them in a closed room.

The bushings must be kept in their original packing, and, for bushings with porcelain insulators, in their original position, that is with the PF tap to-wards the bottom, as indicated by the yellow label put on the head of the bushing and reproduced in fig. 4.

On request, for a long period storage (greater than one year) the bushings can also be shipped with the lower part protected by a rigid container, hermetic and containing silicagel salt, or by a metallic container, oil filled and hermetic: bushings so protected can be shipped and stored for a long time even in the most unfavourable weather conditions.

The temperature range acceptable for the storage is from -25 to +50 °C.

For special requirements regarding low ambient temperatures (see paragraph 5), where special o-rings are foreseen, the bushings can be stored at temperature up to – 55°C.

When the bushing is taken out from the storage is necessary to make a visual check to be sure about the good conditions of any part.



CAUTION

During the period prior the final installation of the bushing on the transformer, special care must be taken in order to avoid that the lower part of the bushing remains outside and in very humid places for long periods. The lower part of the bushing is enclosed in a resin-moulded envelope, which is not hygroscopic, but nevertheless it is better to keep the bushing in a dry ambient.

Until the bushing is not installed on the transformer it has to be considered as an apparatus for indoor installation.

3 LIFTING AND TRANSPORTATION

The bushing type PNO is sturdy, nevertheless, in order to avoid dangerous movements, it is better to follow the suggested options.

3.1. PACKED BUSHING

The case containing the bushings can be easily lifted with a tackle by applying the ropes on the points and with the inclination as indicated in fig.6.

Some indications appear also in the packing case. During handling the case has to be maintained as horizontal as possible, with a maximum inclination of 15°, to be sure that the bushings inside have no problem of nitrogen internal migration from the head to the body.

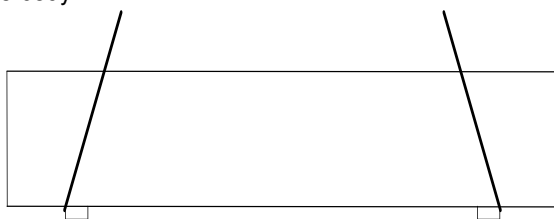

Fig. 6

3.2. UNPACKED BUSHING

To take the bushing out of the case, operate as indicated in Fig. 7 to Fig. 8.

The best way to transport the unpacked bushing is to keep it in vertical position; this can be done with a rope between the second and third (from the top) petticoat of the porcelain as indicated in fig. 7.

If the air side is made, the rope has not to be fixed between petticoats, because there is the risk to damage them. So place the rope between the head and the first petticoat.

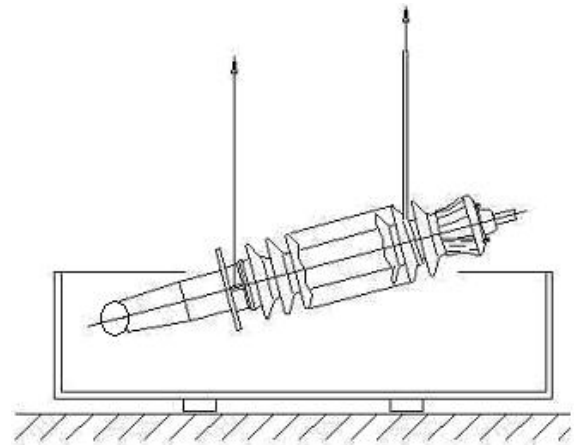

Fig. 7

On the flange of bushings two holes M12 are foreseen. They can be used for the connection to earth or, if necessary, to apply two eyebolts for lifting, or to tighten two screws working as extractors during the dismount from transformer, in case of difficulties.

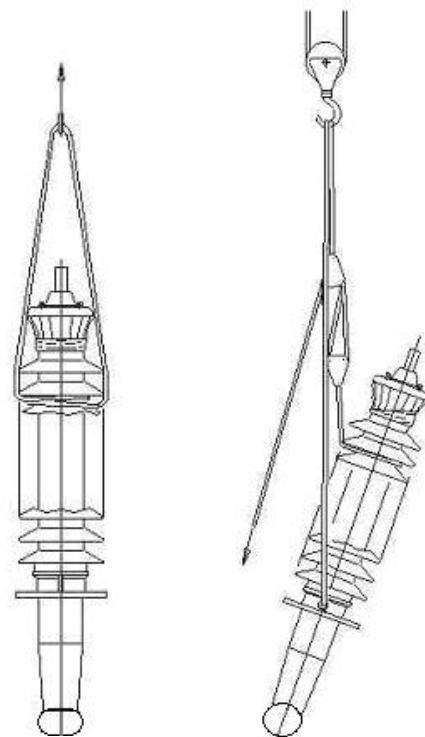

Fig. 8a

Fig. 8b

CAUTION

This is a delicate operation. Before starting the handling, be sure that the ropes are well fixed.

All these operations must be made only by expert people.



Inclined Mounting

If the bushing has to be mounted in inclined position, it will be necessary to apply the rope as in fig. 8b and manually adjust the inclination.

CAUTION

In all the operations of handling it will be necessary to avoid to put the bushing with the head lower than the tail (fig. 10), or to rotate the bushing, in order to be sure that no nitrogen goes in the lower part of the bushing. The maximum allowable inclination is 15° (fig. 10), the maximum rotation is 30° (fig. 9).

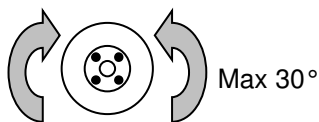

Fig. 9

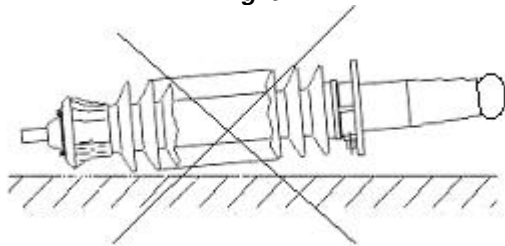

Fig 10

3.3. SHIPMENT TO THE END USER

The shipment of the bushings by the transformer manufacturer after the installation on the machine, for the inspection tests, must be made with the original packing or with a new one, made with the same principles.

Particularly the bottom parts of the bushings must be enclosed with the protection bag.

Silicagel salts, if used to protect the oil side from humidity, have to be checked: if they have absorbed humidity (i.e. if they are pink colour), they have to be dried into an oven (i.e. brought back to blue colour).

CAUTION

When the bushing is positioned in horizontal position, make sure to follow the indications written in the yellow label of fig. 4, positioned on the head: the bushing has to be positioned with the PF tap towards the bottom.

4 INSTALLATION ON THE TRANSFORMER

Before installation, keep the bushing in vertical position for 24 hours and gently rock it to release any residual of nitrogen gas, which may have been trapped in the insulation. If withstand voltage test has to be applied,

keep the bushing for at least 48 hours in vertical position, prior to make the test.

The installation of the bushing on the transformer and the connection to the insulated connection coming from the winding, must be executed according to the following information, depending of the bushing's type.

4.1. DRAW LEAD CONNECTION

In this type of execution, the current in the bushing is carried out directly by the lead coming from the transformer's winding, up to the lug placed in the upper part of the bushing (fig. 11 and fig. 12).

Use one or more copper leads having total section that gives a current density not higher than 2÷2.5 A/mm².

Carry out the assembly as follows, making reference to fig. 11 and fig. 12:

- The lug must be removed from the head of the bushing in order to make the connection: to disassemble the HV top terminal cap (1), remove the 4 x M8 screws and lock washers (4), which secure it to the bushing head (5). Pull the HV top terminal (1) from the lug (2), keeping the terminal well centered on the axis of the bushing. The necessary force is small (about 10 kg) because the multicontact blades (3), located inside the terminal, press softly on the smooth surface of the lug (2). Verify that the o-ring remains seated in the recessed gasket retention groove.

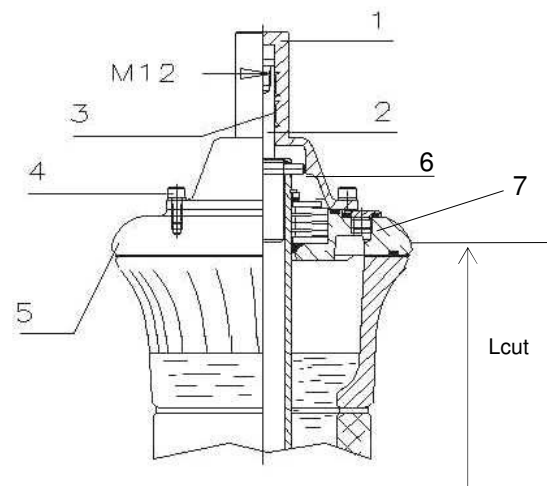

Fig 11

- Remove the locking pin (6) from the lug hole.
- Remove the copper lug (2) from the central tube of the bushing;
- Cut the connection at a right size Lcut plus 20 mm for the soldering of the lug; note that the size Lcut is indicated on the "bushing overall dimensions" drawing, supplied with the bushing's order confirmation;



- Make a hole, in the lug (fig. 12), having diameter at least 2 mm higher than that of the connection and max. 2 mm lower than that of the lug;

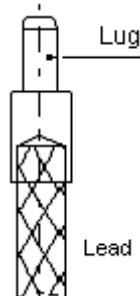

Fig. 12

- Make the connection, through brazing, of the draw lead to the copper lug;
- Fix a thread to the lug, using the M12 hole (fig. 11);
- Place the gasket on the flange on the transformer;
- Slide inside the central bushing's tube from the bottom the lug with the lead;
- Lift and install the bushing according to the instructions of par. 3.
- Align the hole in the lug with the hole in the central tube and secure the lug in position by reinstalling the locking pin (6);
- Be sure the pin is centred;
- Mount the terminal on the lug as described hereunder;
- Place the bolts on the flange of the bushing.
- Insert the HV terminal (1) on the lug, keeping the terminal well centered on the axis of the bushing. The necessary force is small (about 10 kg) because the multicontact blades, located inside the terminal, press softly on the smooth surface of the lug. The top terminal cap will hold the pin in place. Tighten the screws by a moment of 13 Nm. The gasket placed between the two pieces, assures the transformer oil tightness and for this reason it is necessary to block the terminal before filling the transformer with oil. The gasket which is necessary to assure the tightness between the oil of the bushing and the oil of the transformer is not involved in this assembly. The external line connector to the HV terminal must be of compatible material. Clean well the terminal and apply a specific grease for electrical contact and then assembly the connector to the HV terminal.

For a better bushing's tail insulation, it is advisable to protect the lead coming from the winding of the transformer with paper; it is suggested to insulate with a minimum layer of 1,5 mm and a maximum diameter of 2 mm smaller than the internal one of the tube (to allow the oil circulation).

4.2. DRAW ROD CONNECTION

In this type of execution, the conductor is rigid and removable (fig. 13).

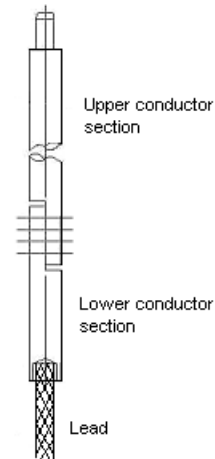

Fig. 13

The rigid conductor can be sectioned in two parts (fig. 13), in order to make easier the transport of the transformer.

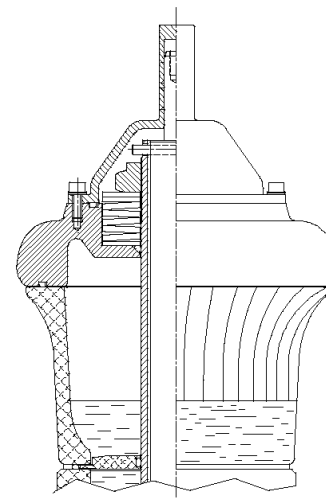

Fig. 14

The procedure is similar as above (fig. 14), but now instead of a lug it is used a conductor that is placed inside the bushing all along it and coming out from the bottom part.

The connection coming from the transformer has to be soldered to the lower extremity of this conductor.

4.3. BOTTOM CONNECTION

In this type of execution, the current is carried directly by the central bushing on-piece conductor from the H.V. terminal (fig. 15) to the bottom one (fig. 16).

In this case the top terminal has not to be dismantled. It is fixed with four M8 screws to the bushing head and



has the only function of covering the bushing's internal spring system.

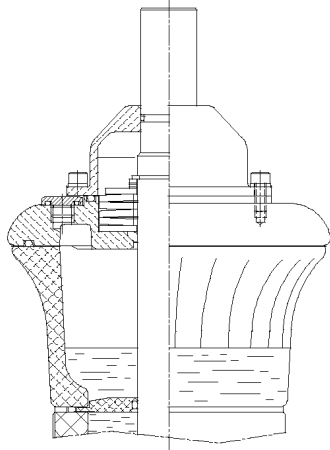

Fig. 15

CAUTION

In the bottom connection execution, the top HV terminal must not be dismantled.

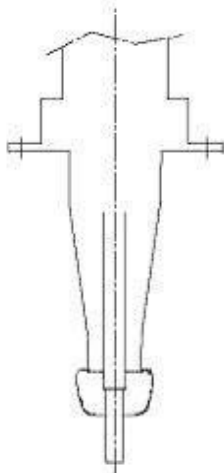

Fig. 16

4.4. OIL SIDE SHIELD

The bottom end of the bushing is shielded by a suitable aluminium electrode. It has the function of increasing the dielectric strength in oil and screen the connection between the lead coming from the transformer winding and the bushing itself.

There are two shield's versions, depending of the type of bushing:

- Fix deflector (fig. 16): in this case the shield can not be removed because it is fixed to the bushing's body;
- Deflector removable upwards (fig. 17): it can be unscrewed upwards.

In the second execution, in a suitable slot on the thread an o-ring is placed in order to act as a brake against a

possible deflector's movement due to vibrations during service. Take care that this o-ring remains in its slot during deflector dismantling and mounting.

Note that the removable shield can be unscrewed easily, and for this reason it has to be dismantled and mounted only at hand, and not with the aid of any tool, in order to not allow any rotation of the internal condenser core.

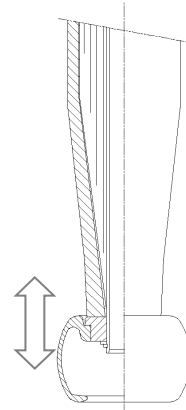

Fig. 17

CAUTION

During handling, take care to not damage the external finishing coat of the dielectric shield, important in the dielectric strength of the bushing oil side.

4.5. ARCING HORNS

Adjustable arcing horns can be provided for all the bushings. On the flange there are 4 threaded holes (placed in orthogonal axis). The lower arcing horn has to be first screwed and then blocked with the nut. On the head there are the 4 fixing screws of the terminal. The upper arcing horn is provided with a connector and is fixed with one of these screws.

The regulation of the spark distance will be made in accordance with the insulation coordination of the Network. The following table 1 gives the suggested discharge distances between arcing horns.

Rated voltage (kV)	"H" discharge distance ±10% (mm)
52	320
72.5	450
100	600
123	750
145	900
170	1000

Table 1



OIL-TO-AIR BUSHINGS SERIES PNO VOLTAGE FROM 52 TO 170 kV

IS 2608 GB

Page 11 of 18

Instruction Manual

Rev. D – Aug. 2019

4.6. OIL FILLING OF THE TUBE OF THE BUSHING

It is foreseen that the bushing operates with the inner tube filled with the transformer's oil at least up to the flange, in order to improve the bushing cooling.

After the closure of the bushing, it is necessary to make the vacuum on the transformer and then fill it with oil.

In case the oil filling is made from the top of the transformer without the vacuum treatment, it is necessary to be sure that the oil level reaches the bushing flange, without the presence of air bubbles.

For this purpose, the flange is provided with a plug which allows the air to flow out (fig. 18).

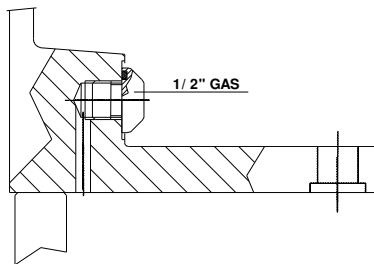

Fig. 18

Furthermore, lift a little the HV terminal (fig. 11 item 1) in order to allow the air to go out and complete the filling of the transformer and of the lower part of the inner tube of the bushing.

Bushings can withstand the vacuum conditions and temperature (up to 90°C) which occur during the treatment of the live part made inside the transformer case.

CAUTION

The characteristic of withstanding vacuum and temperature refers to new bushings. In case of old bushings, it must be considered the natural derating and ageing of the gaskets.

4.7. CONNECTION TO BUCHHOLZ RELAY

A 1/2" GAS plug is placed on the bushing flange (fig. 18) in order to:

- Connect the relay tube, if foreseen;
- Eliminate the air pocket which may be formed during some executions and by the filling of the upper part of transformer not under vacuum.

In this case we suggest unscrewing the plug and left the air flowing. When the oil begins to come out close the plug.

5 TEMPERATURE LIMITS

Bushings of the series PNO are designed for operation at temperatures according to IEC 60137 Standard.

Ambient temperature: Maximum: + 40°C

Max. daily mean: + 30°C

Minimum: - 25°C

Oil temperature: Maximum: +100°C

Max. daily mean: + 90°C

The over-temperatures allowed are in accordance to IEC 60137 Standard.

For special requirements regarding low ambient temperatures (up to -55°C) special o-rings are foreseen, made of nitrile mixtures for low temperatures. The spring closing system is calibrated in order to maintain the bushing's hermeticity at these extreme conditions and the oil maintains its proprieties. For any other special or different condition please inform Grid Solutions SpA and ask the permission to put in service the bushings.

6. SERVICE AND MAINTENANCE

6.1. METAL PARTS

The flange and the metallic components of the oil expansion vessel of the bushings are made of Aluminium alloy casting and do not require any special surface treatment / maintenance.

Only in case of installation in aggressive environment (i.e.: coastal, high pollution, high salinity), it's recommended to protect said metal parts with a layer of antirust coating.

6.2. CHECKS AFTER INSTALLATION

After the installation on the transformer it is advisable to make a check of the bushing capacitance and $tq\delta$.

Normally the measurement (C1) must be carried out between the HV terminal and the Power Factor tap (schematised in fig. 19).

During operation, the PF tap must be grounded maintaining screwed its grounding cap.

The capacitance values measured in Grid Solutions HV laboratory are shown in the test report of the bushings.

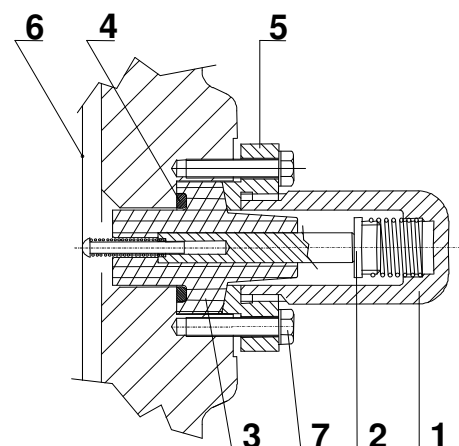



- 1 - Closing and grounding cap (removable)
- 2 - Measurement electrode
- 3 - Insulating bushing
- 4 - Gaskets
- 5 - Mounting flange
- 6 - Last layer
- 7 - Fixing screw (irremovable)

Fig. 19
Power factor tap (standard)

On request bushings with rated voltage 245 kV can be provided with PD (Voltage) tap, which is suitable either for the connection to a Potential Device or for the measurement of the power factor (fig. 21).

In bushings provided of PD tap the measurement can be carried out between the HV terminal and PD tap (C1) and another one between PD and PF tap (C2).

If present and not used, the Potential Device tap has to be grounded maintaining screwed its proper tap (see fig. 21).

If present and used, it has to be grounded through the connected measuring instrument.

WARNING

The PF tap has to be grounded during the normal operation of the bushing.
Do not apply voltage to the bushing if the PF cap is removed. The cap grounds the tap connection.

It is advisable to check that the cap of the PF tap is well screwed (tightening torque: 2 Nm). A forgetfulness of this generates during service a voltage on the tap that exceeds the insulation dielectric strength: this may lead to a catastrophic failure.

Upon request on the bushing's flange it can be mounted another type of PF tap (fig. 20), according to the French Standard NFC 52062.

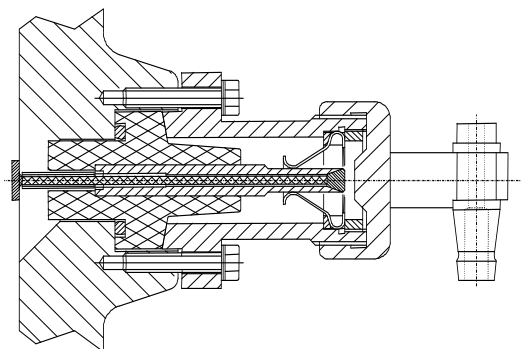

Fig. 20
Power factor tap (on request)

WARNING

Don't unscrew the screws item 7 of fig. 19, that fix the PF flange to the bushing.

If accidentally this operation happens some oil goes out from the bushing and the electrical contact between the internal condenser body and the flange can be damaged.

If a Potential Device is connected to the potential device tap, we recommend to fill of oil the internal part of the connection through the oil filling plug placed in the upper part of the tap (fig. 21 - item 8), to avoid possible internal and dangerous sparking.

If not used the voltage tap can remain empty, but we recommend filling it with mineral oil to prevent the entrance of moisture, that during the years can cause the corrosion of the tap connection contact, with dangerous sparking problems.

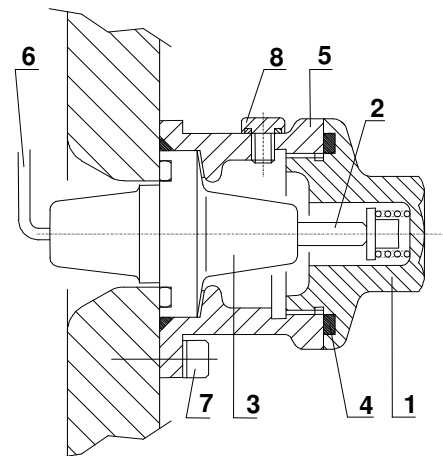

- 1 - Closing and grounding cap (removable)
- 2 - Measurement electrode
- 3 - Insulating bushing
- 4 - Gasket
- 5 - Mounting flange
- 6 - Internal connection
- 7 - Fixing screw (irremovable)
- 8 - Oil filling screw

Fig. 21

Potential Device tap (voltage tap)

WARNING

If the Potential Device tap is not used, we recommend checking if the cap of the oil filling screw (fig. 21 item 8, tightening torque: 13 Nm) have been properly applied and screwed. On the contrary moisture entering can cause the corrosion of the tap connection contact, with dangerous sparking problems.



OIL-TO-AIR BUSHINGS SERIES PNO VOLTAGE FROM 52 TO 170 kV

IS 2608 GB

Page 13 of 18

Instruction Manual

Rev. D – Aug. 2019

6.3. DISASSEMBLY OF THE BUSHING

To disassembly the bushing, operate according to the constructive solution adopted for the transformer, in parallel with the following suggestions:

- Bring the oil until a level lower than the bushing flange;
- Withdraw the terminal from the lug (fig. 11 and fig. 14). For this operation it is necessary to draw the terminal in longitudinal way and, at the same time, rotating a little in clockwise and counter clockwise direction.
- Secure a pulling device to the hole foreseen in the top of the lug.
- Remove the locking pin;
- Fix the bushing like indicated in par. 3;
- Remove the bolts that fix the flange and lift the bushing following the indications given in par 3.

6.4. MAINTENANCE

The bushings PNO are hermetically sealed and therefore an excellent preservation in time of the dielectric properties of the oil paper is ensured. As for the preservation of the active part, these bushings require no maintenance.

It is recommended to perform every 5 years the measurement of the dielectric losses ($\tan\delta$).

As for the preservation of the external surfaces, the manufacturer suggests performing the following inspections.

Porcelain

Check for chips, cracks and contamination. Minor chips maybe painted with an insulating varnish to obtain a glossy finish which will prevent dirt and moisture attack. Bushings with major chips or cracks which appreciably decrease the creepage distance should be removed from service and replaced.

Wash periodically the porcelain surfaces, on which dust, saline compounds, combustion resituates, dirt, oil and other deposits may easily collect and reduce consequently the flashover value.

If the transformer has to be put in service during winter, it is recommendable before to clean the bushing's porcelain from ice or snow that can reduce the dielectric withstand capability.

HV terminals

Check the connections in order to avoid poor contacts and consequent overheating.

Make particular care to the air side connections, more subject to oxidation than the oil side ones.

In case of connections surfaces very oxidised, clean them slightly passing a fine sandpaper, paying attention to not damage the silver (or tin) layer, if

present. After this operation, clean well the surfaces with a light solvent (for example alcohol).

Power factor tap

Check the proper location of the tap cap and its suitable complete screwing (tightening torque: 2 Nm) in order to prevent entrance of moisture (fig. 19).

Potential device tap (Voltage tap)

If present and not used, check the proper location and the suitable complete screwing either of the tap cap and the oil filling screw, in order to prevent entrance of moisture (fig. 21). Voltage tap if not used can remain empty, but we recommend filling it with mineral oil to prevent the entrance of moisture, that during the years can cause the corrosion of the tap connection contact, with dangerous sparking problems.

Oil level

Check the oil level of the bushing and add oil if necessary. The refilling can be done throughout the tap positioned in the upper part of the head (item 7 - fig. 11, fig. 14), near the HV terminal, by using some transformer mineral oil, accurately treated and degassed. Close the cap with a tightening torque of 100 Nm.

The refilling of the gas cushion on the top head of the bushing with nitrogen or dry air is not strictly necessary.

In case the oil level would go down, check carefully if any external leakage is present. If nothing will be detected, then refill the bushing. If the oil level still goes down it is necessary to remove the bushing from the service and to repair it.

CAUTION

To prevent oxidation of the bushing oil and humidity entering, the filling plug has to be closed just after the conclusion of the refilling operation.

The oil inside the bushing is not toxic and perfectly miscible with mineral transformer oil, both from the physical and chemical point of view and from the dielectric and thermal properties.

6.5. MEASUREMENT OF DIELECTRIC LOSSES

Test in the factory

Standard IEC 60137 states that the oil-paper bushings must have a $\tan\delta$ less than 7×10^{-3} .

The measurement is performed in our Test Laboratory by means of a Schering bridge (Tettex type) at the voltages requested by the Standards.

All values are shown in the Test Report.

Measurement at the voltage of 10 kV is carried out in order to have a reference value for comparison with measurements made at site during the service of the bushing.



OIL-TO-AIR BUSHINGS SERIES PNO VOLTAGE FROM 52 TO 170 kV

IS 2608 GB

Page 14 of 18

Instruction Manual

Rev. D – Aug. 2019

Test on the bushing installed on the transformer

With the bushing already installed on the transformer and the HV terminal disconnected, the measurement can be performed by means of a bridge, by applying a voltage of 10 kV between the HV terminal and PF tap (or PD if present), maintaining grounded the flange (C1 measurement). The bushing is considered good if a $tg\delta$ less than the maximum one established by the Standards is measured.

If a $tg\delta$ higher than the above one is measured, please contact Passoni & Villa that will decide if it is necessary to make other tests before removing the bushing from service or to ship it back, in order to make a complete check and eventually to carry out an oil treatment or eventually to replace the active part with another of new manufacture.

In order to measure the Co value (capacitance between the PF tap and flange) the flange has to be supplied with a voltage maximum of 2 kV and the PF tap has to be connected to the bridge.

In case of presence of PD tap, this one can be supplied with a max voltage of 10 kV and the PF tap has to be connected to the bridge (C2 measurement).

A field measurement of $tg\delta$ and capacitance can differ from the measurements carried out in the factory due to the different conditions of test and relevant accuracy: for this reason, a light shifting (max 10% for $tg\delta$) is acceptable. Furthermore, the installation conditions, due to stray capacitances, can affect the capacitance value.

For this it is advisable to measure capacitance and $tg\delta$ upon the installation and use these values as base for future comparison measurements.

6.6. CHECKS ON OLD BUSHINGS

Before remounting an old bushing it is advisable to carry out a tightness test and an electrical check.

6.6.1. Tightness test

Fill completely the bushing through the oil filling plug placed in the top bushing's head (item 7, fig. 11) with treated oil and regulate the pressure at 2 bar relatives for 24 hours.

Make a visual check, than restore the oil level. No leakages have to be detected.

6.6.2. Electrical checks

The old bushings are suitable for service if, as regards the values of reception test, there are no increase higher than (note: values only indicatives):

- 10% for the capacitance C1 (this assure that there isn't a perforation between two layers);
- 30% for $tg\delta$ of capacitance C1;
- 100% for $tg\delta$ of capacitance Co.

An increase of the last value means a derating of the dielectric characteristic of the external layers of the

paper and/or of the oil in the interspace between the condenser body of the bushing and the external housing.

6.7. EXTRAORDINARY CHECKS

If the electric measurement detects a $tg\delta$ higher than the limits it is suggested to carry out an oil sampling (see par. 6.8) and to perform the following tests:

- Humidity content

Original value: ≤ 10 ppm

During working: ≤ 20 ppm

- Dielectric strength

Original value: ≥ 62 kV/2,5 mm

During service: ≥ 45 kV/2,5 mm

- Dielectric losses ($tg\delta$)

Original value: $\leq 7 \cdot 10^{-3}$

During working: $\leq 12 \cdot 10^{-3}$

- Gas chromatography (DGA)

Reference to Standards (IEC 60599, IEC TR 61464)

If these checks give negative results, it is necessary to ship back the bushing to the manufacturer which will execute a complete set of electrical tests and eventually will decide to make an oil treatment to the bushing or to replace the active part with another one of new construction.

6.8. OIL SAMPLING

CAUTION

The operation is to be obviously carried out when the line is off.

The abovementioned operations involve, on the whole, a sampling of about 0.2-0.3 litres of bushing oil.

The oil taken out shall be restored by adding the same quantity of transformer mineral oil, accurately treated and degassed. The refilling must be done through the plug located on the top of the bushing's head (item 7, fig. 11), which must be closed immediately after the end of the operations.

CAUTION

The oil sampling operation must be carried out as quickly as possible and in a period with a low humidity level, in order to not pollute the oil inside the bushing.



6.8.1. Bushings from 52 to 123 kV

The oil filling plug is situated in the head of the bushing, near the high voltage terminal (item 7, fig. 11)

Due to the method used to take the oil sampling we underline that is not possible to evaluate the right content of nitrogen (N₂) and oxygen (O₂).

One must take care to CO and CO₂ quantity, because these gases are contained in a certain quantity in the air and are consequently able to pollute the oil.

Equipment

To carry out oil sampling from a bushing, it is necessary to have the following elements:

- A 100-150 cm³ oil syringe (Lab. Type);
- A two-way cock with a suitable connection to the syringe;
- A semi-rigid pipe;
- A syringe cap;
- Adhesive tape.

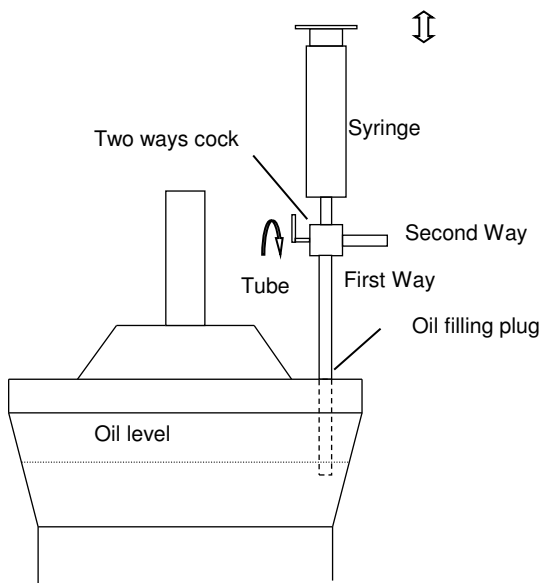

Fig. 22

Preparation

Operate as follows (see fig. 22):

- Clean the oil sampling plug zone accurately;
- Prepare all the syringe apparatus, with the cock and the tube;
- Unscrew the oil sampling tap and put the pipe, on which the cock and the syringe are applied in sequence, in the bushing's head. Be sure that the pipe is immersed in the oil;

- Open the 1st way of the cock, closing the cock's 2nd way;
- Drain oil from the bushing, sucking it with the syringe, letting it flow out until there are no more air bubbles;
- Shut off the cock's 1st way opening the cock's 2nd way;
- Empty the syringe;
- Shut off the cock's 2nd way opening the cock's 1st way.
- Fill in again the syringe with some oil (about 10-20 cm³);
- Close the cock's 1st way and open the 2nd way of cock;
- Empty the syringe.

Oil sampling

- Close the cock's 2nd way opening the 1st way;
- Drain oil from the bushing, slowly sucking it with the syringe up to appropriate volume (approx. 60-100 cm³);
- Shut off 2nd way of the cock;
- Extract the tube from the bushing;
- Set the syringe with the cock being up;
- Unplug the cock and place the closing cap;
- Clean the syringe and block it with adhesive tape on which you will write down the bushing part number;
- Overturn the syringe and keep it with its cap down;
- Screw the oil filling plug on the head of the bushing;
- Clean the oil sampling zone accurately.

6.8.2. Bushings from 145 to 170 kV

On the bushing flange there is a screw plug, that is positioned at about 180° from the PF tap: this is the oil sampling plug (fig. 23).

Equipment

To carry out oil sampling from a bushing having the oil sampling plug, we need the following:

- A 150 cm³ oil syringe (item 4) (Lab. Type);
- A two-way cock (item 3) with a suitable connection to the syringe;
- A semi-rigid pipe (item 2);



OIL-TO-AIR BUSHINGS SERIES PNO VOLTAGE FROM 52 TO 170 kV

IS 2608 GB

Page 16 of 18

Instruction Manual

Rev. D – Aug. 2019

- An appropriate plug that can be screwed at one side on the bushing sampling plug and that can be connected at the other side on the tube (item 1). Note that the flange hole has a thread of 1/4" GAS;
- A syringe cap;
- Adhesive tape.

Preparation

Operate as follows (fig. 23):

- Clean the plug zone accurately;
- Prepare all the syringe apparatus, with the cock (item 3) and the pipe (item 2);
- Loose the filling tap located on the top of the bushing's head (item 7 - fig. 14);

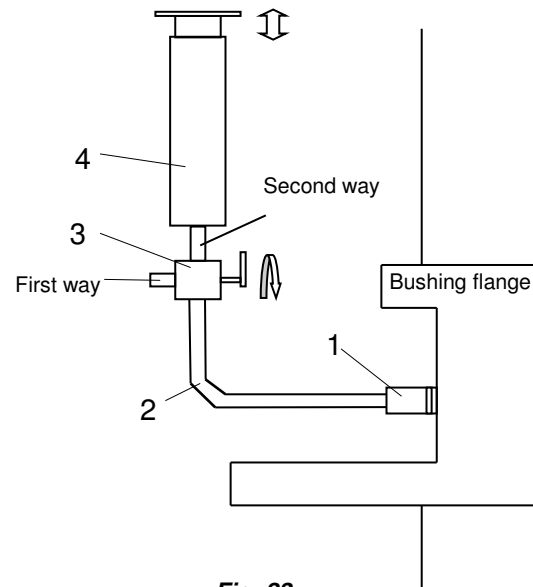

Fig .23

WARNING

The operation of loosening the filling tap located on the head of bushing is important to ease the oil exit and above all to remove the low depression that can be generated inside the bushing in case of low temperature, phenomenon that can allow a dangerous air incoming in the bushing from the sampling plug.

- Unscrew the oil sampling plug and screw the connecting cap (item 1), on which the tube (item 2) is to be applied in sequence. Note that when the oil sampling plug is unscrewed, some oil will exit from the hole in a continuous manner: in fact inside there is no valve. The flow out of oil is low, but the apparatus is to be linked immediately;
- Wash the syringe with oil two times by repeating the following operations:
 - Open 2nd way of cock (item 3);
 - Fill in slowly the syringe with some oil (about 10-30 cm³), in order to wash it and to let the exit of the air bubbles contained in the pipe;
 - Open 1st way of cock (item 3);
 - Empty the syringe (item 4);
 - Close 1st way of cock (item 3).

Oil Sampling

For sampling please follow these instructions:

- Close the 1st way of the cock (item 3) and open the 2nd way;
- Slowly fill the syringe with the oil up to the appropriate volume (approx. 60-100 cm³);
- Shut off 2nd way of the cock (item 3);
- Remove the syringe by unplugging the cock (item 3) from the tube (item 2);
- Set the syringe with the cock (item 3) being up;
- Unplug the cock (item 3) and place a closing cap;
- Clean the syringe and block it with adhesive tape on which you will write down the bushing part number;
- Overturn the syringe and keep it with its cap down;
- Remove the pipe from the plug, unscrew the plug and screw immediately its proper tap, to avoid further oil flow from the bushing.

If the oil flows out too slowly, it is suggested to rise the internal pressure of the bushing by means of an injection of nitrogen through the filling hole positioned in the upper part of the head (M16 threaded), near the HV terminal: in this way the nitrogen injected goes only in the gas cushion situated in the head of the bushing, which has to be maintained in vertical position (or near the vertical position).

After the oil sampling the bushing pressure must be restored to the previous value, that is zero bar relatives (ambient pressure).



6.8.3. Bushings of 245 kV

On the bushing flange there is a valve (see fig. 24 and 25) positioned in closed position: it is the oil sampling valve. On this valve it can be screwed a metallic closing disc. To make the oil sampling it is necessary to dismantle this closing disc (if present) and to mount another one provided by a suitable connection.

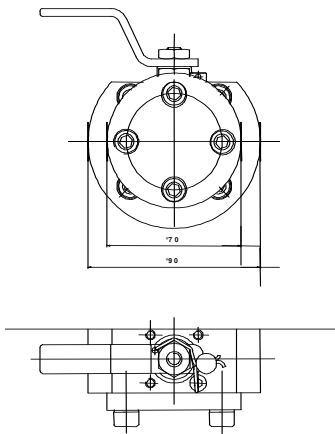

Fig. 24

Equipment

To carry out oil sampling from a bushing, we need the following:

- A 150 cm³ oil syringe (item 4) (Lab. Type);
- A semi-rigid pipe (item 2);
- An appropriate little flange suitable for fixing to the sampling valve (having 4 holes positioned at 90° each others, with a holes wheelbase of 50 mm; the o-ring housing is positioned on the valve body). This little flange will have a suitable connection to the sampling semi-rigid pipe (item 1);
- A two-way cock (item 3) with a suitable connection to the syringe;
- A syringe cap;
- Adhesive tape.

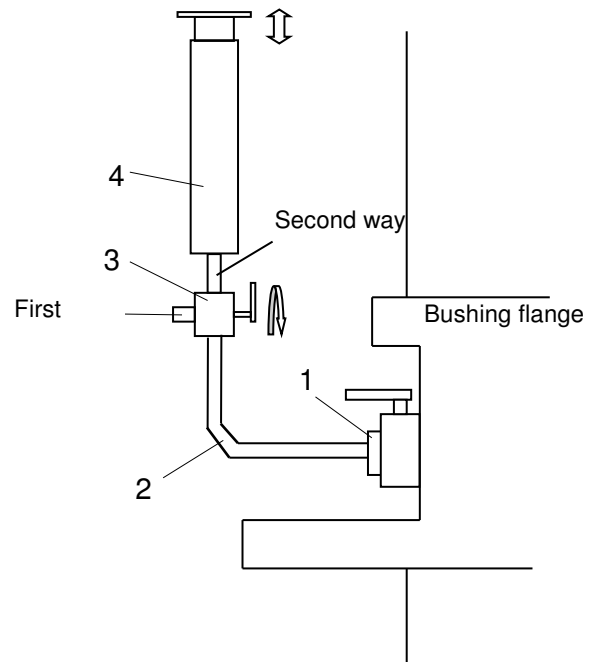

Fig. 25

Preparation

Operate as follows:

- Clean the plug zone accurately;
- Prepare all the syringe apparatus, with the cock (item 3) and the tube (item 2);
- Dismantle the closing flange unscrewing the 4 screws M8 and fix the sampling flange, provided by a suitable connection to the semi-rigid pipe (item 1);
- Wash the syringe with oil two times by repeating the following operations:
 - Open 2nd way of cock (item 3);
 - Fill in slowly the syringe with some oil (about 10-30 cm³), in order to wash it and to let the exit of the air bubbles contained in the pipe;
 - Open 1st way of cock (item 3);
 - Empty the syringe;
 - Close 1st way of cock (item 3).

Oil sampling

For sampling please follow these instructions:

- Close the 1st way of the cock (item 3) and open the 2nd way;
- Slowly fill the syringe with the oil up to the appropriate volume (approx. 60-100 cm³);
- Shut off both 2nd way of the cock (item 3) and the bushing's valve;



**OIL-TO-AIR BUSHINGS SERIES PNO
VOLTAGE FROM 52 TO 170 kV**

IS 2608 GB

Page 18 of 18

Instruction Manual

Rev. D – Aug. 2019

WARNING

To ease the oil exit and to remove the low depression that can be generated inside the bushing in case of low temperature, phenomenon that can allow a dangerous air incoming in the bushing from the sampling valve, it is suggested to loosen the filling tap located on the top bushing's head.

- Remove the syringe by unplugging the cock (item 3) from the tube;
- Set the syringe with the cock (item 3) being up;
- Unplug the cock (item 3) and place a closing cap on the syringe;
- Clean the syringe and block it with adhesive tape on which you will write down the bushing part number;
- Overturn the syringe and keep it with its cap down;
- Remove the pipe from the plug, unscrew the sampling flange and screw the original one;
- Screw completely the filling tap on the head of the bushing (item 7 - fig. 14).

7. DISPOSAL AT THE END OF LIFETIME

The bushing consists of the following material:

Component	Material	Action
Winding conductor	Copper or aluminium alloy	Dismount and recycle
Terminals and bottom plates	Copper, aluminium alloy or brass; optional silver or tin coating	Dismount and recycle
Insulating oil	Mineral oil acc. IEC60296	Recycle
Winding	Cellulose paper and thin aluminium foils	Dispose or thermo-destruction
Nuts, bolts, washers and springs	Stainless steel, carbon steel	Dismount and recycle
Top oil expansion vessel	Borosilicate glass	Dismount and recycle
Flange and extension	Aluminium alloy	Dismount and recycle
PF tap and cover	Nickel or tin coated brass, tin coated copper	Dismount and recycle
Top insulator	Either porcelain acc. To IEC60672 or composite insulator made of: Glass fibre reinforced epoxy Silicone	Dispose or thermo-destruction
Insulator fittings	Aluminium alloy	Dismount and recycle
Bottom insulator	Either porcelain acc. IEC60672 or epoxy resin	Dispose or thermo-destruction
Bottom shield	Aluminium alloy covered with either epoxy paint or epoxy resin	Dismount and recycle